

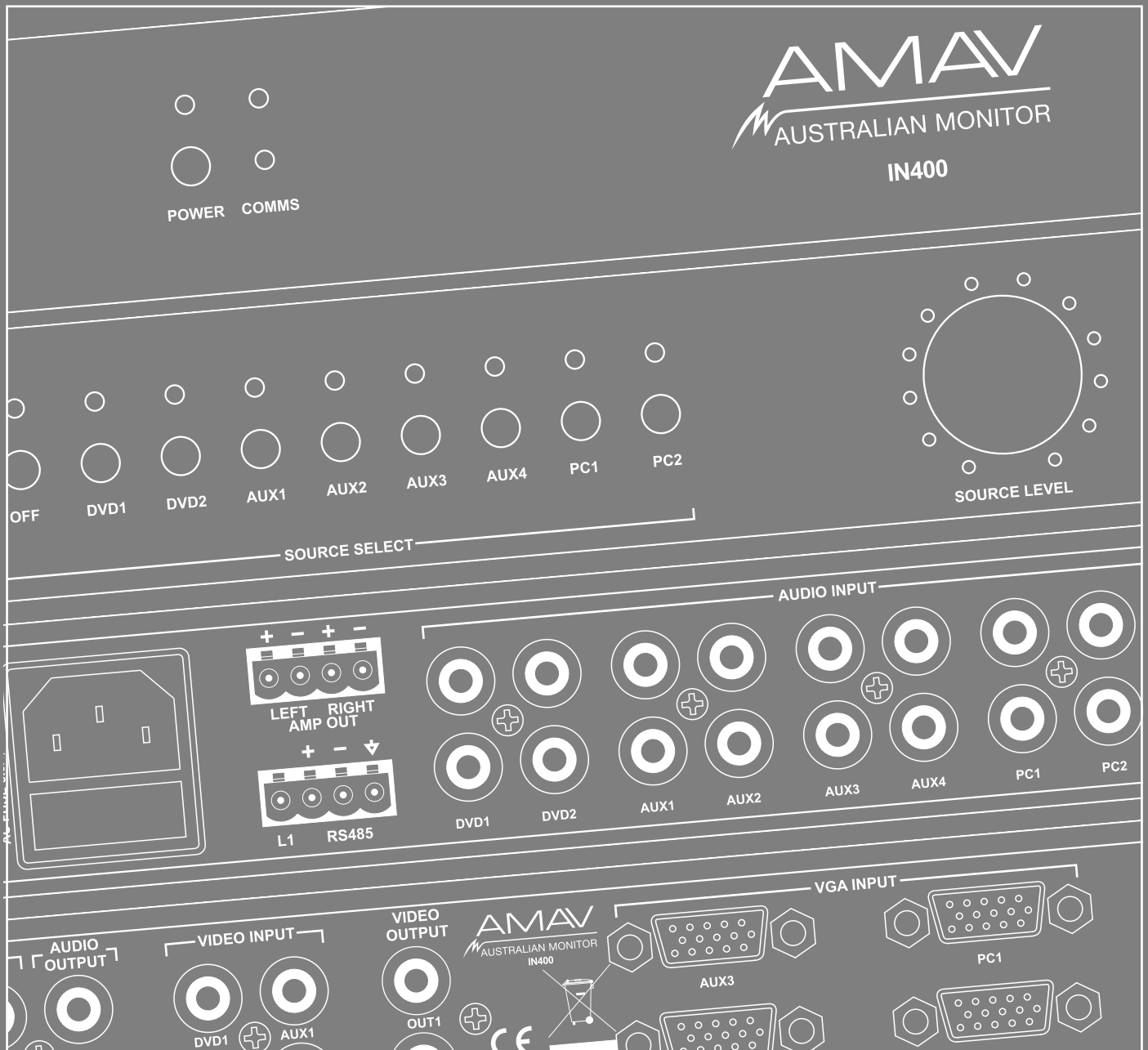

INNOVATION SERIES IN400

AV SWITCHING AMPLIFIER INSTALLATION AND OPERATION MANUAL



IMPORTANT SAFETY INFORMATION

1. Read these instructions.
2. Keep these instructions.
3. Heed all warnings.
4. Follow all instructions.
5. Do not use this apparatus near water.
6. Clean only with dry cloth.
7. Do not block any ventilation openings. Install in accordance with the manufacturer's instructions.
8. Do not install near any heat sources such as radiators, heat registers, stoves, or other apparatus (including amplifiers) that produce heat.
9. Do not defeat the safety purpose of the polarized or grounding-type plug. A polarized plug has two blades with one wider than the other. A grounding type plug has two blades and a third grounding prong. The wide blade or the third prong are provided for your safety. If the provided plug does not fit into your outlet, consult an electrician for replacement of the obsolete outlet.
10. Protect the power cord from being walked on or pinched particularly at plugs, convenience receptacles, and the point where they exit from the apparatus.
11. Only use attachments/accessories specified by the manufacturer.
12. Use only with the cart, stand, tripod, bracket, or table specified by the manufacturer, or sold with the apparatus. When a cart is used, use caution when moving the cart/apparatus combination to avoid injury from tip-over. 
13. Unplug this apparatus during lightning storms or when unused for long periods of time.
14. Refer all servicing to qualified service personnel. Servicing is required when the apparatus has been damaged in any way, such as power-supply cord or plug is damaged, liquid has been spilled or objects have fallen into the apparatus, the apparatus has been exposed to rain or moisture, does not operate normally, or has been dropped.
15. This appliance shall not be exposed to dripping or splashing water and that no object filled with liquid such as vases shall be placed on the apparatus.
16. Plug this apparatus to the proper wall outlet and make the plug to be disconnected readily operable.
17. Main plug is used as disconnected device and it should remain readily operable during intended use. In order to disconnect the apparatus from the mains completely, the mains plug should be disconnected from the mains socket outlet completely.
18. **WARNING:** To reduce the risk of fire or electric shock, do not expose this apparatus to rain or moisture.
19. An appliance with a protective earth terminal should be connected to a mains outlet with a protective earth connection.

PRÉCAUTIONS DURANT UTILISATION

1. LISEZ ces instructions.
2. Tenez ces instructions.
3. Notez tous les avertissements.
4. Suivez toutes les avertissements.
5. N'utilisez pas ce produit près de l'eau (la piscine, la plage, le lac, etc.).
6. Nettoyez seulement avec une étoffe sèche.
7. Ne bloquez aucuns trous de ventilation. Installez en accord avec les instructions du fabricant.
8. N'installez près aucunes sources de chaleur comme radiateurs, registres de chaleur, fours ou les autres équipements (y compris amplificateurs) qui produisent la chaleur.
9. Ne défaites pas le but de sécurité de la fiche polarisée ou base-type. Une fiche polarisée a deux tranchants avec un plus large que l'autre. Une fiche de base type a deux tranchants et une troisième pointe de base, le tranchant large ou la troisième pointe est fourni pour votre sécurité. Si la fiche donnée ne conforme pas votre prise de contact, consultez un électricien pour remplacement de la prise de contact obsolète.
10. Protégez le cordon de secteur contre être marchée dessus ou pincez en particulier aux fiches, aux douilles de convenance, et au point où ils sortent de l'appareil.
11. Seulement utilisez attachements/accessoires spécifiés par le fabricant.
12. Utilisez seulement avec un chariot, un stand, un trépied, un support ou une table indiquée par le fabricant, ou vendue avec l'appareil. Quand un chariot est utilisé, faites attention en déplaçant la combinaison d'appareil/chariot pour éviter de se déséquilibrer. 
13. Arrachez la fiche du dispositif durant éclair et orage ou quand pas utilisé pour longues périodes de temps.
14. Référez au personnel qualifié de service pour toutes réparations. La réparation est donnée quand le système a été endommagé à n'importe façon, par exemple un fil ou une fiche endommagé(e) de la source d'alimentation. Avoir été exposé à pluie ou humidité, n'opère pas normalement, ou avoir été tombé.
15. L'appareil ne doit pas être exposé aux écoulements ou aux éclaboussures et aucun objet ne contenant de liquide, tel qu'un vase, ne doit être placé sur l'objet.
16. Branchez l'appareil à une source appropriée et faire que la prise à débrancher soit facilement accessible.
17. La prise du secteur ne doit pas être obstruée ou doit être facilement accessible pendant son utilisation. Pour être complètement déconnecté de l'alimentation d'entrée, la prise doit être débranchée du secteur.
18. **AVERTISSEMENT:** Pour éviter le risque d'incendie ou de chocs électriques, ne pas exposer cet appareil à la pluie ou à l'humidité.
19. Un appareil avec la borne de terre de protection doit être connecté au secteur avec la connexion de terre de protection.

The Innovation series from AMAV is a huge step forward in the interfacing and management of audio and visual sources. Integrating a host of smart, high end features in a compact package that offers the end user extremely simple control over their complex audio visual system. The Innovation series is as ground breaking as it is simple to operate.

The IN400 is a compact AV switching amplifier with a host of extra features available to the AV integrator. With 8 AV inputs as well as mix in, stereo line output, 2 composite video outputs, VGA video output, 80 watt per channel powered outputs, IR control, RS485 control and video away from audio split the IN400 is perfect for boardroom, lecture theatre or training facility installations as a stand alone control unit or as part of a larger system interfacing with a third party control system.

INTRODUCTION	3
FRONT PANEL	4
REAR PANEL	5
SETUP	6
INSTALLATION	7
BLOCK DIAGRAM	8
DIMENSIONS	9
SPECIFICATIONS	10

AUS, EUR, USA
 Copyright 21st Aug 2008
 REV A 21st Aug 2008
 REV B 9th Dec 2008
 REV C 8th Apr 2010
 REV D 7th June 2010

WARNING!

TO PREVENT FIRE OR SHOCK HAZARD, DO NOT USE THE PLUG WITH AN EXTENSION CORD, RECEPTACLE OR OTHER OUTLET UNLESS THE BLADES CAN BE FULLY INSERTED TO PREVENT BLADE EXPOSURE.
 TO REDUCE THE RISK OF FIRE OR ELECTRIC SHOCK, DO NOT EXPOSE THIS APPLIANCE TO RAIN OR MOISTURE.
 TO PREVENT ELECTRICAL SHOCK, MATCH WIDE BLADE PLUG TO WIDE SLOT, FULLY INSERT.



The lightning flash with arrowhead symbol, within an equilateral triangle, is intended to alert the user to the presence of uninsulated "dangerous voltage" within the product's enclosure that may be of sufficient magnitude to constitute a risk of electric shock to persons.

CAUTION

**RISK OF ELECTRIC SHOCK
DO NOT OPEN**

WARNING: TO REDUCE THE RISK OF ELECTRIC SHOCK, DO NOT REMOVE COVER (OR BACK). NO USER SERVICEABLE PARTS INSIDE. REFER SERVICING TO QUALIFIED SERVICE PERSONNEL.



The exclamation point within an equilateral triangle is intended to alert the user to the presence of important operating and maintenance (servicing) instructions in the literature accompanying the appliance.

Rating plate and caution marking are marked on the back enclosure of the apparatus

FRONT PANEL

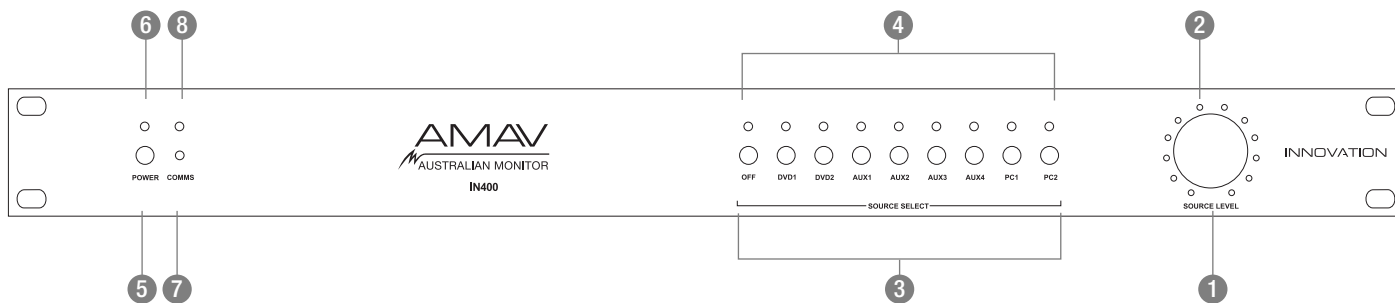

1 MASTER VOLUME

This pot controls the audio output level.

2 MASTER VOLUME LEDS

These LED's indicate the position of the volume control. They do not indicate the strength of the signal.

3 SOURCE SELECT SWITCHES

These switches select the input that is routed to the audio and video outputs.

4 SOURCE SELECT LEDS

The LED above the switch indicates when the channel is being routed to the outputs.

LED State

1. A solid LED means that both audio and video from that source is routed to the respective outputs.
2. A long flashing LED means that audio from that source is routed to the audio output.
3. A short flashing LED means that video from that source is routed to the video output.

Source audio and video splitting is achievable through RS485. See the section on Communications on page 6 for more information.

5 POWER SWITCH

This switch switches the unit on.

6 POWER ON LED

This indicates the unit is on.

7 IR SENSOR

This is the sensor used for IR control. A hand held remote control is supplied with the IN400. Line of sight is required for the remote control to work.

8 COMMS LED

This LED indicates when data is sent or received via IR or RS485.

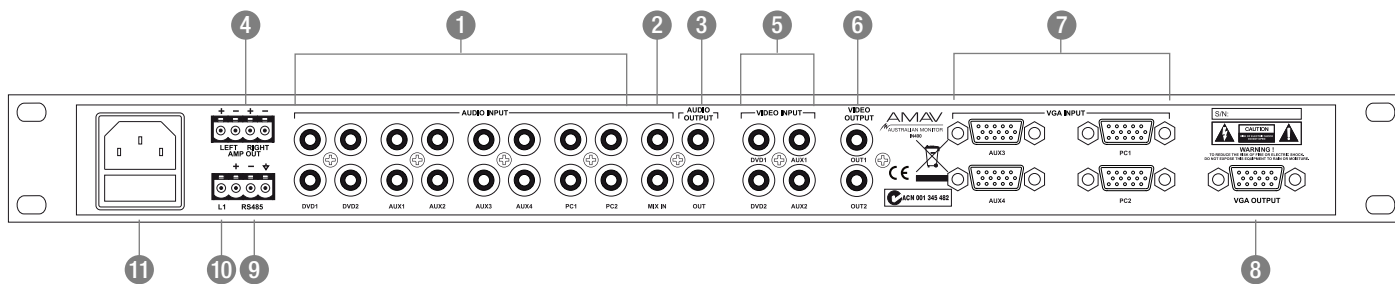

1 AUDIO INPUT

Sources

These are the RCA unbalanced line level audio inputs for each of the 8 sources. The top RCA connector is the left channel, bottom RCA connector is the right channel.

2 MIX IN

This input is not switched but mixes with the selected audio source. The bass/treble/volume controls do not affect this input. This feature can be used in paging environments or emergency systems in conjunction with the L1 trigger input.

3 AUDIO OUTPUT

These are the left (top) and right (bottom) RCA unbalanced line level outputs.

4 AMP OUT

The IN400 has a built in audio stereo power amplifier. The input signal is paralleled from the AUDIO OUTPUT. The power amp is rated at 2 x 80W into 4 ohm, 2 x 50W into 8ohm. The minimum load is 4ohm. The outputs are on a 5.08mm pluggable connector.

5 VIDEO INPUT

These are RCA unbalanced 75ohm composite video inputs for the DVD1/DVD2/AUX1/AUX2 sources.

6 VIDEO OUTPUT

These are the RCA unbalanced 75ohm composite video outputs. OUT1 and OUT2 output the same signal but they are individually buffered. These outputs only output the signal from DVD1/DVD2/AUX1/AUX2 sources if selected.

7 VGA INPUT

These are high density 15pin D connector VGA inputs for the PC1/PC2/AUX3/AUX4 sources.

8 VGA OUTPUT

This is the high density 15pin D connector VGA output. This output only outputs the signal from PC1/PC2/AUX3/AUX4 sources if selected.

9 RS485

This 5.08mm pluggable connector socket is provided for external control of the IN400 using RS485.

10 L1

This input is used to mute the audio outputs. The MIX IN is not affected. This feature can be used in paging environments or emergency systems. Short it to the RS485 ground pin to activate it.

11 IEC MAINS INPUT SOCKET

This is a standard IEC 3 pin socket (IEC320-C14). It accepts a standard IEC mains cable, provided. The fuse draw contains the mains fuse and a spare. The mains fuse is a time lag (slow blow) HRC 20mm x 5mm fuse.

The ratings are:

230V Model T3.15A

120V Model T6.3A



Always replace the fuse with one of the same value and type.



Note: Always disconnect power to the amplifier before replacing fuses.

SETUP

RS485 Settings

Baud Rate: 9600
No. of Bits: 8
Stop Bit: 1
Parity Bit: None

Word Structure

! - Start byte
XXX - 3 byte command
: - delimiter
XXX - 3 byte data
<CR> - carriage return
All bytes are ASCII characters.

RS485 Setup

The IN400 data port is an RS485 serial data port. Twisted pair cabling should be used when connecting RS485 devices, such as CAT3, CAT5, CAT5e or CAT6 UTP cabling. RS485 data networks should be wired in a 'daisy chain' configuration with a maximum of 32 devices in the chain. The IN400 is not terminated so may be inserted anywhere in the data network. If the IN400 is being used at the end of a chain, a 120ohm (characteristic impedance of UTP) terminating resistor should be connected between the + and - connections.

The IN400 has built in failsafe bias circuitry so there are no need for external biasing resistors. The maximum length of the chain is 500m.

Data Commands

COMMS	DESCRIPTION
!VER:??<CR>	Version request. Device replies with !VER=xyz where xyz is the version ID of the firmware.
!GMD:??<CR>	Global Mode request. Device replies with !GMD=00x, where x is 0 if global mode is not active and 1 if global mode is active.
!LOK:??<CR>	Panel Lock request. Device replies with !LOK=00x, where x is 0 if panel lock is not active and 1 if panel lock is active.
!PWR:??<CR>	Soft Power request. Device replies with !PWR=00x, where x is 0 if soft power state is off and 1 if soft power state is on.
!BAS:??<CR>	Bass request. Device replies with !BAS=0xy, where xy is the current setting of bass.
!TRE:??<CR>	Treble request. Device replies with !TRE=0xy, where xy is the current setting of treble.
!VOL:??<CR>	Volume request. Device replies with !VOL=xyz, where xyz is the current setting of volume.
!MUT:??<CR>	Mute request. Device replies with !MUT=0xy, where x represents the audio mute and y represents the video mute.
!SRS:??<CR>	Source request. Device replies with !SRS=0xy, where x represents the audio source and y represents the video source.
!GMD:000<CR>	Global Mode set. Global mode is deactivated. Device replies with !GMD=000 when done.
!GMD:001<CR>	Global Mode set. Global mode is activated. Device replies with !GMD=001 when done.
!LOK:000<CR>	Panel Lock set. Panel lock is deactivated. Device replies with !LOK=000 when done.
!LOK:001<CR>	Panel Lock set. Panel lock is activated. Device replies with !LOK=001 when done.
!PWR:000<CR>	Soft Power set. Device is put into soft power off. Device replies with !PWR=000 when done.
!PWR:001<CR>	Soft Power set. Device is put into soft power on. Device replies with !PWR=001 when done.
!MUT:0xy<CR>	Mute set. If x is 0, the audio is muted. If y is 0, the video is muted. If x is 1, the audio is unmuted. If y is 1, the video is unmuted. Device replies with !MUT=0ab, where a represents the new audio mute state and b represents the new video mute state.
!SRS:0xy<CR>	Source Select set. The audio source is set to x. The video source is set to y. Device replies with !SRS=0ab, where a represents the new audio source and b represents the new video source.
!VOL:xyz<CR>	Volume set. The volume is set to xyz. The device replies with !VOL=abc where abc is the new volume.
!VOL:+++<CR>	Volume increment. The volume is incremented by 1. The device replies with !VOL=abc where abc is the new volume.
!VOL:---<CR>	Volume decrement. The volume is decremented by 1. The device replies with !VOL=abc where abc is the new volume.
!BAS:0xy<CR>	Bass set. The bass is set to xy. The device replies with !BAS=0ab where ab is the new bass.
!BAS:+++<CR>	Bass increment. The bass is incremented by 1. The device replies with !BAS=0ab where ab is the new bass.
!BAS:---<CR>	Bass decrement. The bass is decremented by 1. The device replies with !BAS=0ab where ab is the new bass.
!TRE:0xy<CR>	Treble set. The treble is set to xy. The device replies with !TRE=0ab where ab is the new treble.
!TRE:+++<CR>	Treble increment. The treble is incremented by 1. The device replies with !TRE=0ab where ab is the new treble.
!TRE:---<CR>	Treble decrement. The treble is decremented by 1. The device replies with !TRE=0ab where ab is the new treble.

Global Mode

When the IN400 is in global mode, changes to the volume and tone affect all the sources.
When not in global mode, changes to the volume and tone affects the selected source.

All installation work should be done with the power disconnected. The following information will help with installation. After installation is complete power up all the sources before turning on the IN400.

POWER CONNECTION

Ensure the mains voltage supply matches the rear of the IN400 (+/- 10%)

Ensure that all system grounds (earth) are connected to a common point. Avoid powering equipment within a system from multiple power sources that may be separated by large distances. This will eliminate ground loops that are heard as 50/60Hz humming or buzzing in speakers and seen as moving or stationary bars on video equipment.

INPUT CONNECTIONS

Audio
All the inputs are unbalanced RCA sockets. Unbalanced RCA wiring should be kept as short as possible. Typically less than 3m.

Video
Video inputs are on either unbalanced RCA sockets (composite) or 15 pin high density female connectors D-connectors (VGA). The maximum cable length for composite video is typically less than 3m for shielded wire and 10m for coaxial before signal degradation. This will depend on the cable quality.

OUTPUT CONNECTIONS

Audio
The line level outputs are unbalanced RCA sockets. Unbalanced RCA wiring should be kept as short as possible. Typically less than 3m.

The amplifier outputs are 5.08mm pluggable connectors. Use the following table for selecting a suitable gauge wire for the cable you are running over a particular distance. The table is for a 1dB drop in level which is generally considered acceptable.

	AWG10	AWG13	AWG14	AWG16	AWG17	AWG18	AWG20	AWG22	AWG24	AWG26
Speaker										
16	279	125	100	75	51	38	26	17	11	6
8	139	62	50	37	26	19a	13	9	6	3
4	70	31	25	19	13	10				

Do not connect a total impedance of less than 4ohm per channel.

OUTPUT CONNECTIONS (cont.)

Video
Video outputs are on either unbalanced RCA sockets (composite) or 15 pin high density female connectors D-connectors (VGA). The maximum cable length for composite video is typically less than 3m for shielded wire and 10m for coaxial before signal degradation. This will depend on the cable quality.

There are two composite outputs for running to 2 different monitors without the need for an external distribution amplifier.

- VGA pin out
- 1 Red out
 - 2 Green out
 - 3 Blue out
 - 4 Monitor ID 2 in
 - 5 Ground
 - 6 Red return
 - 7 Green return
 - 8 Blue return
 - 9 no pin
 - 10 Sync return
 - 11 Monitor ID 0 in
 - 12 Monitor ID 1 in
 - 13 Horizontal Sync out
 - 14 Vertical Sync out
 - 15 reserved (monitor ID 3)

Only pins 1,2,3,5,6,7,8,10,13,14 are used in the IN400.

RS485 CONNECTIONS

The RS485 data port is on a 5.08mm pluggable connectors. Twisted pair cabling should be used. When connecting RS485 devices, such as CAT3, CAT5, CAT5e or CAT6 UTP cabling. RS485 data networks should be wired in a 'daisy chain' configuration with a maximum of 32 devices in the chain. The IN400 is not terminated so may be inserted anywhere in the data network. If the IN400 is being used at the end of a chain, a 120ohm (characteristic impedance of UTP) terminating resistor should be connected between the + and - connections.

The maximum length of the chain is 500m.

BLOCK DIAGRAM

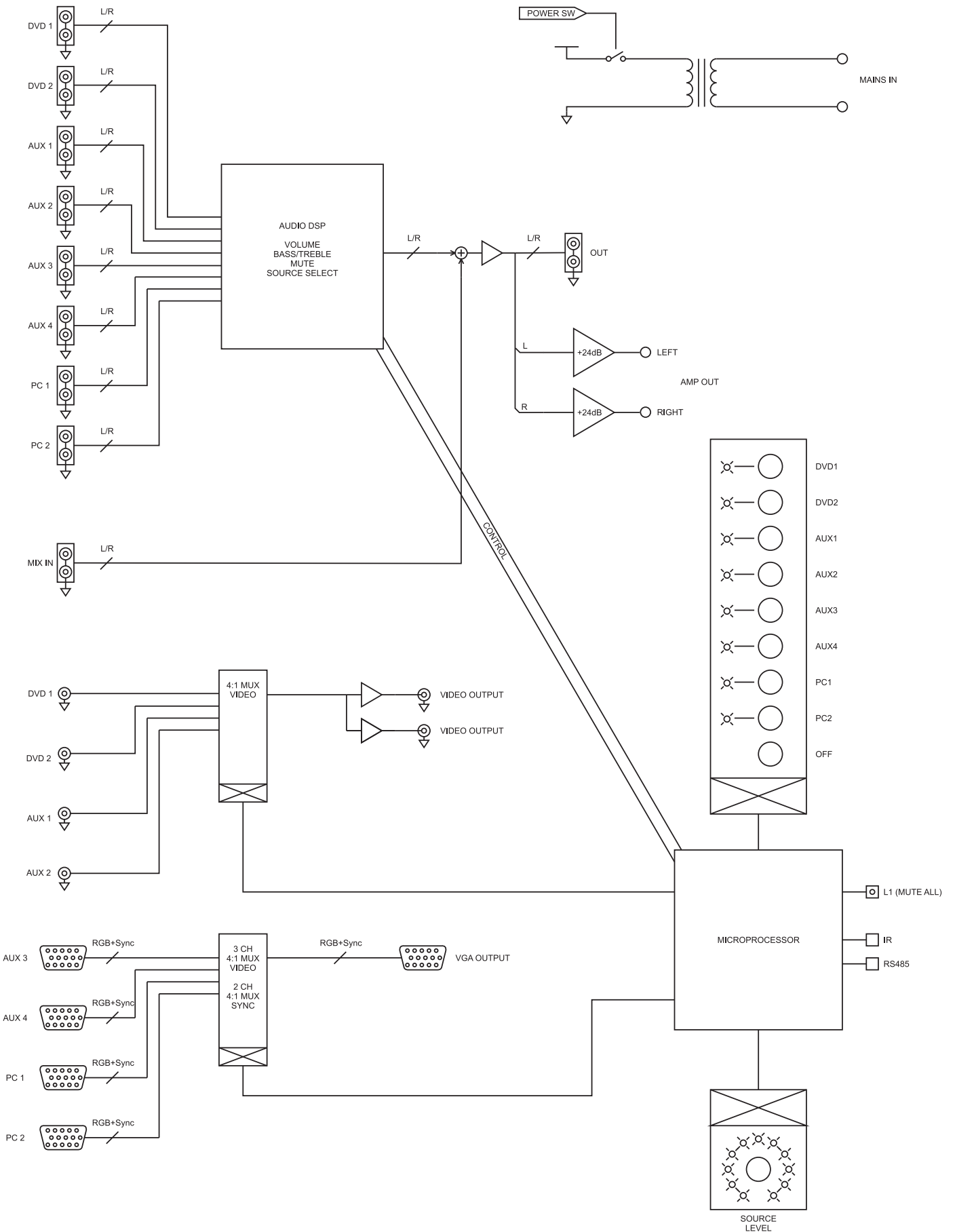

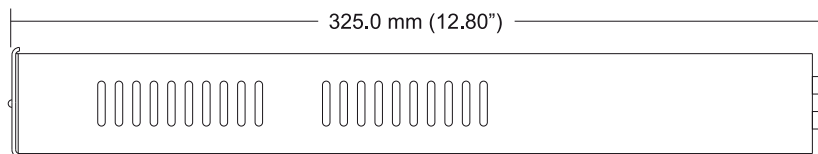
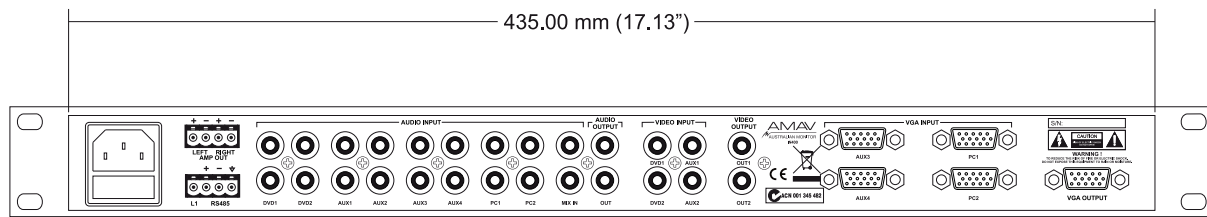
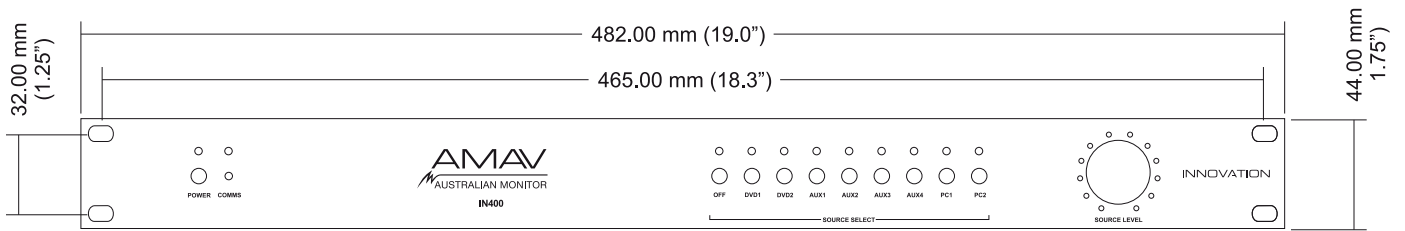

SPECIFICATIONS

POWER OUTPUT (0.5%THD, 1kHz) 8ohm 50W,
4ohm 80W

THD (20-10kHz, 8ohm, -2dBr) Better than 0.1%

Frequency Response(+/-3dB) 20-20kHz

Gain 24dB @ 8ohm

Line Audio THD <0.5%
Noise Floor -90dBu
Frequency Response(+/-3dB) 20Hz-20kHz
Headroom +5dBu

Video VGA High speed RGB+Sync switching
Video Composite 75ohm Buffered outputs
Video follows Audio switching

Comms Type RS485
Baud Rate 9600
No of Data Bit 8
Parity None
No of Stop Bits 1

Power Consumption 1/8th power 150VA (0.65A)

Thermal output 1/8th power 100W (341.2Btu/hr)

SIZE (WXHxD) 482 x 44 x 325mm
19 " x 1.75" x 12.8"

NET WEIGHT 7.0kg
15.4lb

SHIPPING WEIGHT 9.0kg
19.8lb

SHIPPING DIMENSIONS (WXHxD) 520 x 90 x 420 mm
19.0" x 3.5" x 16.5"

AUSTRALIA AND NEW ZEALAND

www.australianmonitor.com.au

SYDNEY

(NSW SALES)

1 Clyde Street
Silverwater
NSW 2128
Private Bag 149
Silverwater NSW 1811
Phone: (02) 9647 1411
Fax: (02) 9648 3698
Email:
nsw@audiotelx.com.au

MELBOURNE

(VIC & TAS SALES)

22/277
Middleborough Road
Box Hill VIC 3128
PO Box 151 Blackburn
South VIC 3130
Phone: (03) 9890 7477
Fax: (03) 9890 7977
Email:
vic@audiotelx.com.au

ADELAIDE

(SA & NT SALES)

31 Walsh Street
Thebarton
SA 5031
PO Box 157
Hindmarsh SA 5007
Phone: (08) 8352 4444
Fax: (08) 8352 4488
Email:
sa@audiotelx.com.au

AUCKLAND

(NZ SALES)

9C Piermark Drive
Albany 0752
New Zealand
PO Box 300-512
Albany 0752
Phone: (09) 415 9426
Fax: (09) 415 9864
Email:
sales@audiotelx.co.nz

CANBERRA

(ACT SALES)

1st Floor,
Campion Street
Deakin ACT 2600
PO Box 109
Deakin West ACT 2600
Phone: (02) 6260 4544
Fax: (02) 6260 4744
Email: gordon.anderson@hillssvl.com.au

BRISBANE

(QLD SALES)

42 Commercial Road
Fortitude Valley
QLD 4006
PO Box 2578 Fortitude
Valley BC QLD 4006
Phone: (07) 3852 1312
Fax: (07) 3252 1237
Email:
qld@audiotelx.com.au

PERTH

(WA SALES)

3/11 Howe Street
Osborne Park WA 6017
PO Box 1281
Osborne Park BC
WA 6916
Phone: (08) 9204 0200
Fax: (08) 9244 3783
Email:
wa@audiotelx.com.au

EUROPE / ASIA / MIDDLE EAST

www.australianmonitor.com.au

INTERNATIONAL SALES

1 Clyde Street Silverwater NSW 2128 Australia
Private Bag 149 Silverwater NSW 1811
Phone: + 61 2 9647 1411
Fax: + 61 2 9748 2537
Email: international@audiotelx.com.au