



Clever Features, Contractor Friendly

ZoneMix3

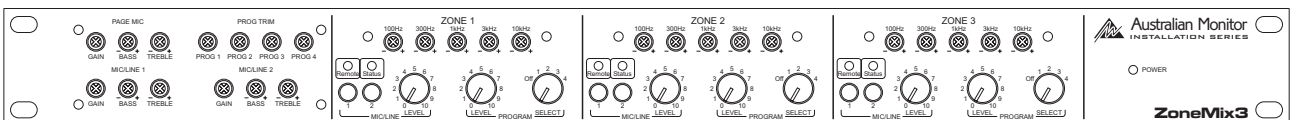

3 Zone Stereo Mixer/Matrix

Installation & Operation Manual



AUS, EUR, USA
Copyright 9th Mar 2004
Rev A: 9th Mar 2004

Internal Revision Info
Rev 1 10/12/03
Rev 2 05/02/04
Rev 3 09/03/04

 <p>CAUTION RISK OF ELECTRIC SHOCK DO NOT OPEN</p> <p>CAUTION: TO REDUCE THE RISK OF ELECTRIC SHOCK. DO NOT REMOVE COVER (OR BACK). NO USER-SERVICEABLE PARTS INSIDE. REFER SERVICING TO QUALIFIED SERVICE PERSONNEL.</p>	 <p>This symbol is intended to alert the user to the presence of uninsulated "dangerous voltage" within the product's enclosure that may be of sufficient magnitude to constitute a risk of electric shock to persons.</p>
<p>WARNING ! TO REDUCE THE RISK OF FIRE OR ELECTRIC SHOCK. DO NOT EXPOSE THIS EQUIPMENT TO RAIN OR MOISTURE.</p>	 <p>This symbol is intended to alert the user to the presence of important operation and maintenance (servicing) instructions in the literature accompanying the appliance.</p> <p>Caution: To prevent electric shock do not use this (polarized) plug with an extension cord, receptacle or other outlet unless the blades can be fully inserted to prevent blade exposure.</p> <p>To prevent electric shock, match wide blade of plug to wide slot, fully insert.</p>

CONTENTS

	Page
1. Introduction	4
2. Front Panel	5
3. Back Panel	7
4. Functional Notes	9
5. Internal Adjustments	10
6. Installation	13
7. SetUp (Step by Step)	15
8. ZM3M - Paging Station	16
9. ZM3R - Remote Control Panel	18
10. Dimensions	21
11. Block Diagram	22
12. Specifications	23

1. INTRODUCTION

The Australian Monitor Zone Mix 3 is an extremely versatile & innovative mixer & signal router. Featuring a broadcast quality audio spec, the Zone Mix 3 allows selection of 4 stereo sources to 3 stereo zones either at the ZoneMix3 or remotely. One stereo source can have selectable priority per zone & each stereo zone boasts 5 stage equalization. The Zone Mix 3 also has the ability to route two independent mic or line signals to any zone or combination of zones. Add to this remote volume controls in each zone & the ZM3M 3 zone paging microphone (both running via inexpensive CAT5 cabling) and you have an extremely high quality Zone selecting mixer at a fraction of the cost of other products in this market.

2. FRONT PANEL

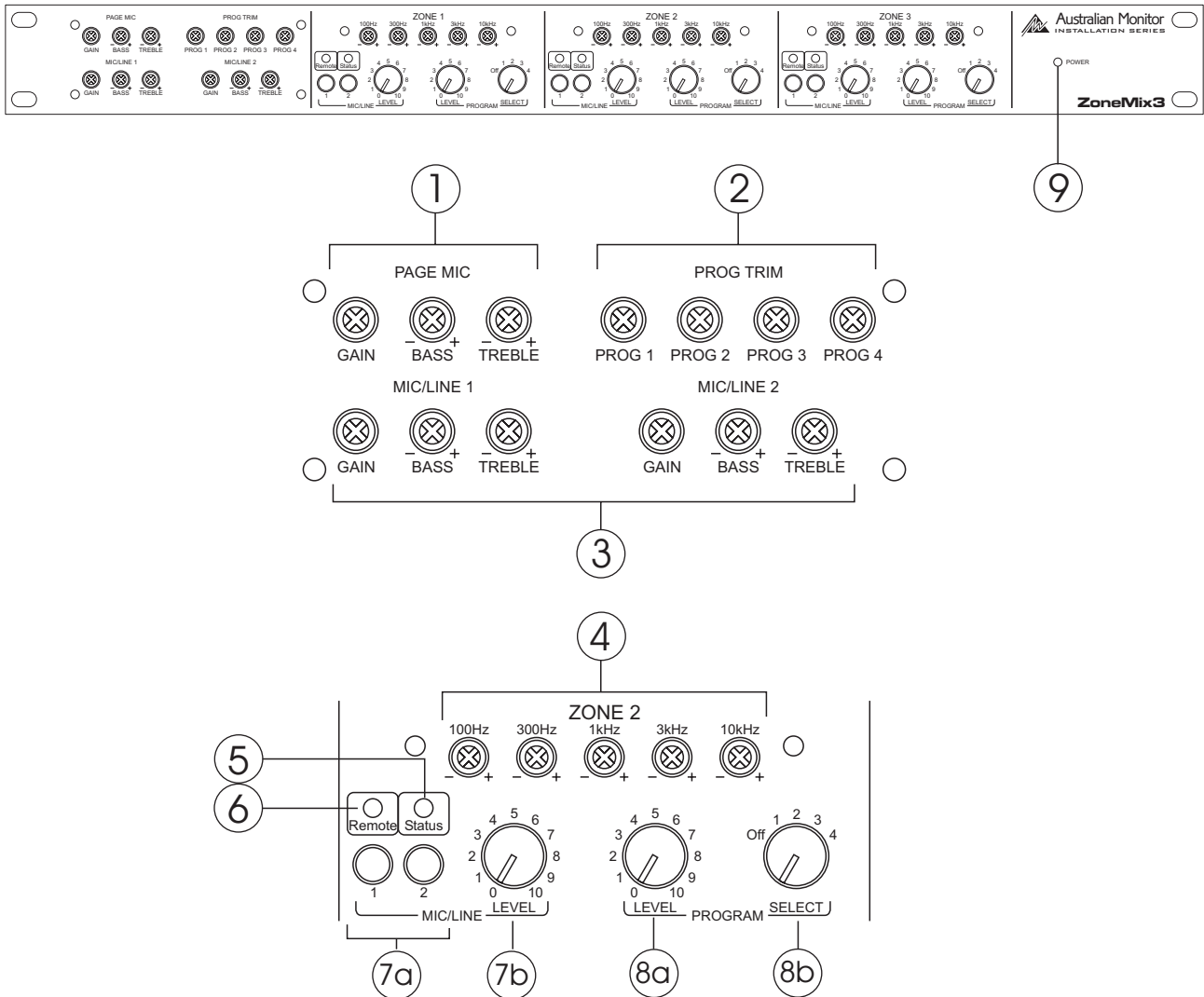

INPUT CONTROL SECTION

Note that there are security panels covering the input section and zone EQ section when first removed from the box. These should be used to prevent incidental tampering.

1. PAGING MIC CONTROL

Gain

This controls the gain of the optional Paging Station microphone. See Paging Station on page 16 for more information on the Paging Station and its use.

Bass

There is +/-12dB of cut and boost at 100Hz. This eq is shelving type.

Treble

There is +/-10dB of cut and boost at 10kHz. This eq is shelving type.

2. PROG TRIM

These four pots control the input trim of the corresponding program inputs. There is no gain from these pots.

3. MIC/LINE CONTROLS

There are two Mic/Line inputs. The following controls are duplicated for each input.

Gain

This controls the gain of the Mic (on the XLR) or Line (on the RCA) input.

Bass

There is +/- 12dB of cut and boost at 100Hz. This eq is shelving type.

Treble

There is +/- 10dB of cut and boost at 10kHz. This eq is shelving type.

ZONE OUTPUT SECTION

4. EQ

The zone eq is 5 band with frequency centres at 100Hz, 300Hz, 1kHz, 3kHz and 10kHz. There is +/- 9dB of cut and boost. The eq is internally defeatable, see Internal Adjustments on page 10.

5. STATUS

This LED gives an indication of OUTPUT signal . It glows green at -30dB and red at 0dBV (1V). This is meant to indicate clip within the system (ie when the amplifier is clipping) rather than indicate clip within the ZoneMix3. When used with Australian Monitor Synergy amplifiers, both LEDS on the ZoneMix3 and the Synergy amplifier will go red simultaneous indicating system clip (with pot at full on amplifier).

6. REMOTE

This LED indicates that the zone is in remote control mode. The program select and volume on the front panel are disabled and are now controlled by the optional remote control panel ZM3R, see Remote Control Panel on page 18.

7. MIC/LINE Control

7a.SELECT

These two push button switches are used to select either or both of the two MIC/LINE inputs to this zone.

7b.LEVEL

This pot controls the mixed level of the two MIC/LINE inputs in this zone.

8. PROGRAM Control

8a.SELECT

This rotary 5 way switch is used to select which program input is selected to this zone.

8b.LEVEL

This controls the level of the program in this zone.

9. POWER Led

This LED indicates there is power to the unit.

3. BACK PANEL

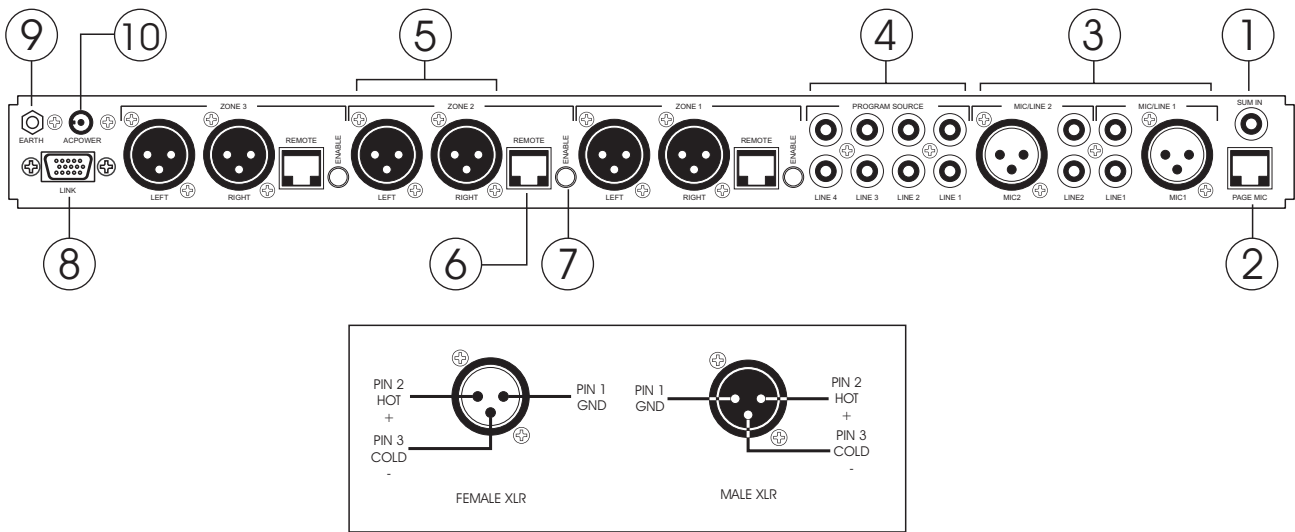

1. SUM INPUT

This RCA line level input is an all zone priority input. See Functional Notes on page 9. The volume control is preset internally and can be adjusted. See Internal Adjustments on page 10. It can be used to receive an emergency evacuation tone or similar signal.

2. PAGE INPUT

This RJ45 connector accepts a CAT5 cable from the optional ZM3M Paging Station. See Paging Station on page 16 for more details.

NOTE: These are **NOT** Ethernet connections.

3. MIC/LINE INPUTS

There are two MIC/LINE inputs. The balanced XLR inputs accept mic level signals. The dual RCA inputs accept line level inputs and are summed to mono internally. Gain and EQ are controlled from the front panel.

These inputs supply 15V phantom power, unless internally disabled. See Internal Adjustments on page 10.

These inputs may have priority over program inputs, if this feature is enabled. See Internal Adjustments on page 10 and Functional Notes on page 9.

4. PROG INPUTS

There are four program inputs. These are stereo RCA line level inputs. Trim is controlled from the front panel. LINE4 is a priority input, if this feature is enabled. See Internal Adjustments on page 10 and Functional Notes on page 9.

5. ZONE OUTPUTS

The zone outputs are configured as stereo left and right as default but can be internally changed to mono.

6. REMOTE PORT

This CAT5 socket is used to connect the optional ZM3R remote control panel for each zone. See Installation Section on page 13 and Remote Control Panel Section on page 18.

7. REMOTE ENABLE

This button puts the zone into remote mode and must be pressed in when using the remote control panel ZM3R. When pressed, the front panel program controls (SELECT and LEVEL) will be disabled. Control is handed over to the remote control panel. If no remote control panel is connected, the program inputs will be off.

8. LINK

This 15 pin high density connector is used to connect two ZoneMix3 units together. When connected together the program sources and the mic/line inputs are linked to the slave unit. The unit needs to be internally configured as master or slave. This is done by moving the link cable. See Internal Adjustments on page 10.

9. EARTH

In some circumstances it may be necessary to ground the unit to eliminate noise in the system. This can be done by using this earth stud.

NOTE: This stud provides a connection to chassis ground. Audio ground is internally tied to chassis ground.

10. AC POWER

This 2.1 mm connector accepts power from the provided 20VAC power supply.

4. FUNCTIONAL NOTES

There are many features hidden in this product that greatly enhance its value. However, it's important to understand how these features work in order to get the best out of the product.

PRIORITY INPUTS

Sum in

Signal on this input will mute program in ALL zones. Level is preset internally and can be adjusted. See Internal Adjustments on page 10.

This input can be used to receive an emergency evacuation tone or similar signal.

Page mic

If the optional ZM3M Paging Station is connected to the system, paging signals will mute program in the zones selected on the ZM3M only.

Mic/Line 1,2

These inputs are set up to mute program. This will only occur if the input is selected into the zone on the front panel. Priority can be disabled for each input, on a per-zone basis (See Internal Adjustments on page 10). If disabled these inputs are mixed with the program sources into the zone outputs, as selected on the front panel.

For example, if Zone 2 is a Bistro and a microphone in the servery is connected to MIC/LINE 1 input and selected in Zone 2, the program would duck in this zone (MIC1 priority is enabled in Zone 2 by default). However if Zone 3 is a bar and a karioke microphone is connected to MIC/LINE 2 input and selected in Zone 3, MIC2 priority should be disabled in Zone 3 so that the microphone will mix with the program source .

Release time

All of the above priority inputs (Sum, Page, Mic/Line) share a common priority level. The release time (for program to come back up) may be selected on a per-zone basis. See Internal Adjustments on page 10.

Prog 4

In venues with a Juke box, the Jukebox should over-ride (mute) any other background music sources that are selected. The LINE4 input is used for this. With this feature enabled, when signal appears on LINE4 it will automatically be selected even if not selected on the front panel or remote control panel. PROG4 priority may be enabled on a per-zone basis. See Internal Adjustments on page 10.

It is undesirable to cut back to other BGM between tracks, so a separate release time adjustment is available for PROG4, with a range of 1-25 seconds (common to all zones). See Internal Adjustments on page 10.

LINKING

If 3 zones is not enough, two ZM3s can be connected together using a single cable in a Master-Slave configuration and enabling this feature. See Internal Adjustments on page 10.

The Master unit will accept all the input sources (both Mic/Line inputs and program inputs), and these will be passed to the Slave unit.

Input gain or trim controls on the master unit are used (see Setup on page 15). The input controls on the slave unit will have no effect.

Use high density 15pin male to male cable wired straight through (pin1 to pin1, pin2 to pin2, etc). A VGA monitor cable may be suitable. This cable should be kept as short as possible.

When operating a system that incorporates two linked ZM3's, a ZM3M connected to the master ZM3 will page into the zones assigned to the master ZM3 only. Similarly, a ZM3M connected to the slave ZM3 will page into the zones assigned to the slave ZM3 only. It is not possible to page 'across' linked ZM3's. If a more sophisticated paging and program distribution matrix is required, then we have available a range of products ideally suited to the purpose. Our DigiPage and DigiPageJr family of products allow for comprehensive paging and program distribution into up to 16 zones. Please contact your local AMIS dealer for more details.

5. INTERNAL ADJUSTMENT

NOTE: To avoid frustration, check this section BEFORE installing your ZM3 in the rack!

NOTE: The following adjustments involve access to the inside of the ZM3 and should only be attempted by a qualified technician. All internal adjustments are accessible by removing the lid of the ZM3. Always turn off the AC power and remove the power cord before accessing the inside of the ZM3.

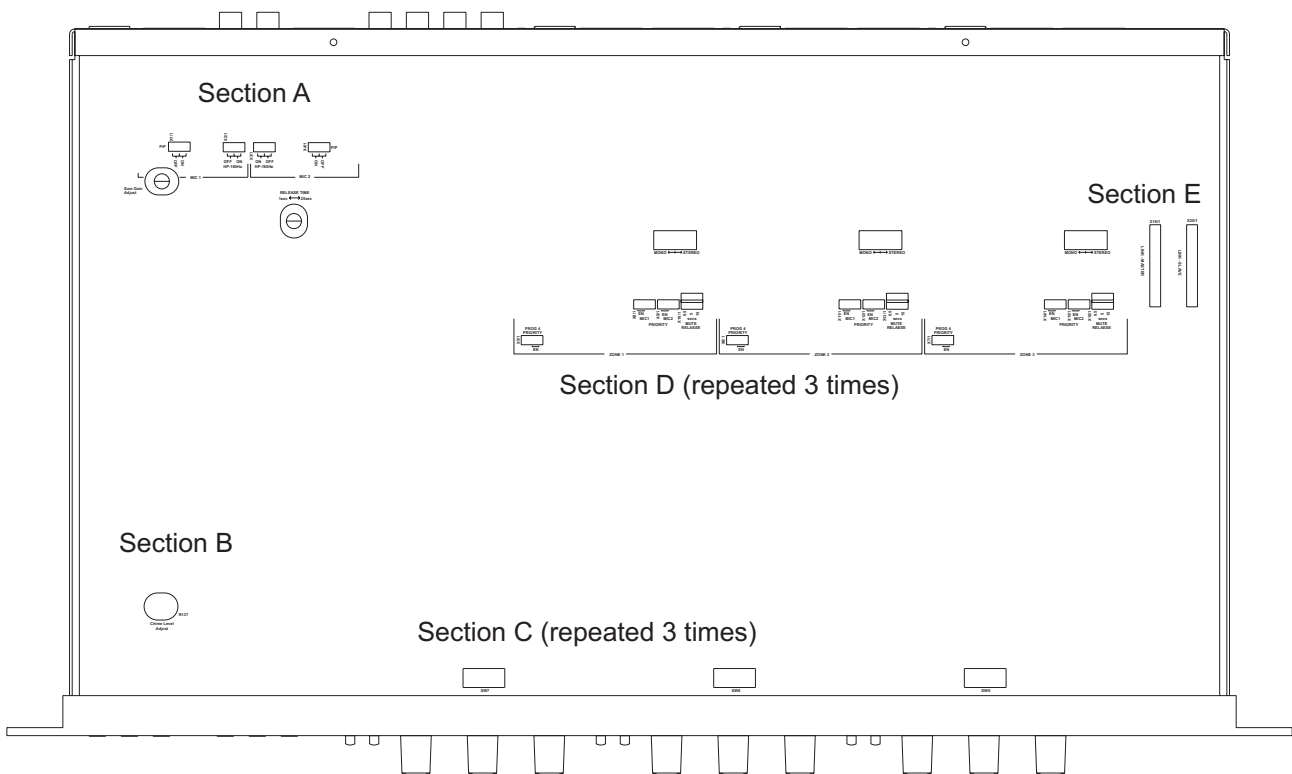

There are many internal adjustments that can be made to configure the ZoneMix3 to perform exactly as you want it. Use the diagram above to locate various controls and refer to the section indicated for a more detailed view and information on that control. Controls are clearly marked on the printed circuit board.

Section A
 Mic/Line 1 - Phantom Power
 Mic/Line 1 - HPF
 Mic/Line 2 - Phantom Power
 Mic/Line 2 - HPF
 Prog 4 Priority release time
 Sum Input level

Section B
 Paging Chime level

Section C
 Zone Eq Bypass

Section D
 Mic/Line 1 Priority
 Mic/Line 2 Priority
 Priority Release Time
 Program 4 Priority
 Output Mono/Stereo Mode

Section E
 Unit Link Setting

SECTION A

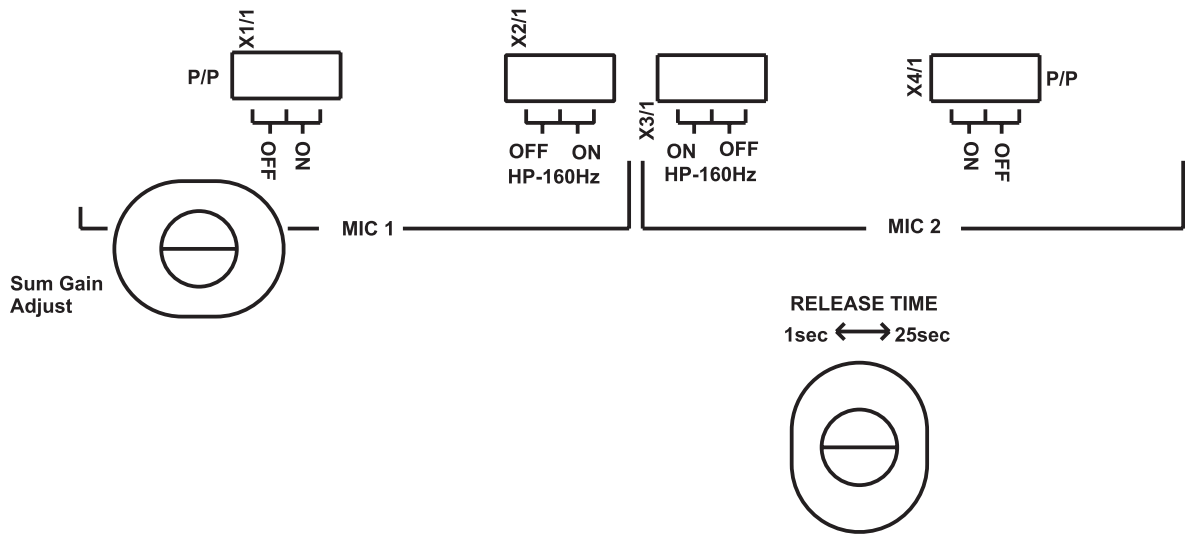

MIC 1, 2

NOTE: PCB markings should be noted carefully as MIC2 is a mirror image of MIC1.

MIC1 refers to MIC/LINE 1 input, and MIC2 refers to MIC/LINE 2 input.

P/P

Phantom Power +15VDC. Default is ON.

HPF - 160Hz

The high pass filter has a crossover at 160Hz and a slope of -6dB/oct. Default is OFF.

RELEASE TIME

Prog 4 Priority release time trimpot 1sec-25sec - Default is 10sec.

See Functional Notes on page 9.

Sum Gain Adjust

Sum Input level 0dB to Off - Default is -6dB.

SECTION B

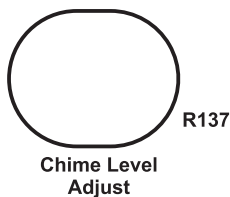

Chime Level Adjust

This pot is for the chime that sounds when a page is made using the Paging Station. Paging Chime level 0dB to Off - Defaults is -6dB.

SECTION C

This section is repeated 3 times (one per zone).



Zone Eq Bypass switch - Eq In/Eq Out. Default is Eq In.

SECTION D

This section is repeated 3 times (one per zone).

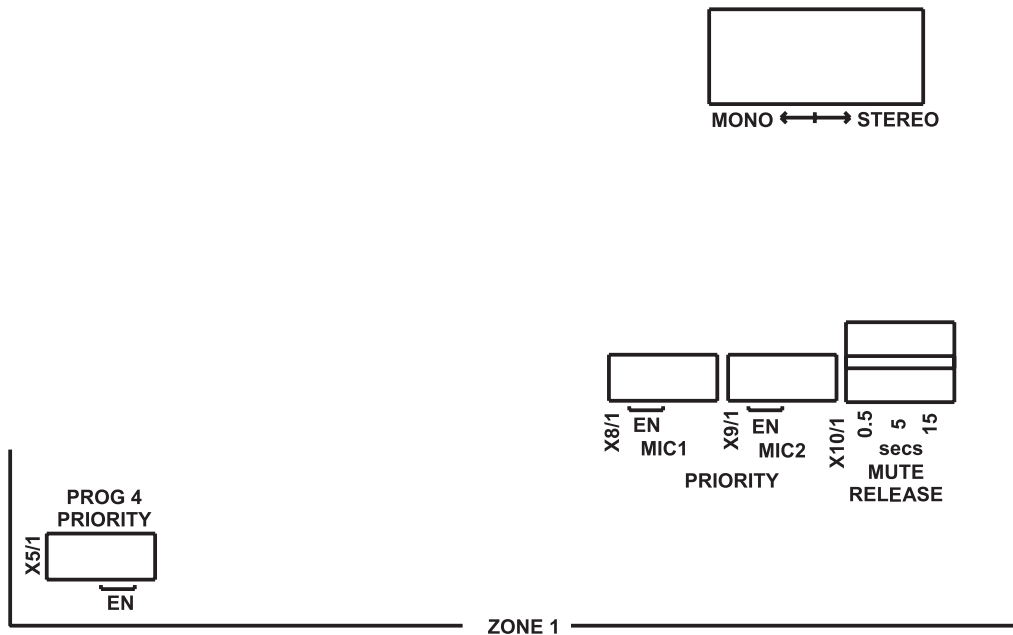

MIC1 refers to MIC/LINE1 input, and MIC2 refers to MIC/LINE2 input. See Functional Notes on page 9 for explanation of priority functions.

PRIORITY

MIC1, 2

Default is EN (enabled).

MUTE RELEASE

Priority Release Time jumper socket - 0.5,5,15 sec. Default is 5sec.

PROG 4 PRIORITY

Program 4 Priority jumper socket - Default is EN (enabled).

MONO-STEREO

Output Mode switch - Mono/Stereo. Default is Stereo.

SECTION E

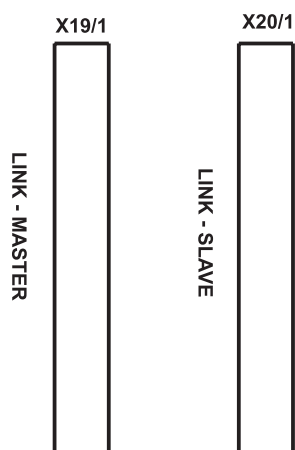

These two sockets are used when linking two ZoneMix3 units.

See Functional Notes on page 9 for explanation of linking.

All input sources are connected to the Master unit. In this unit the linking header should be plugged into the connector labelled LINK-MASTER.

In the other (Slave) unit, the linking header should be moved to the connector labelled LINK-SLAVE.

By default, all units ship as Masters.

6. INSTALLATION

In its basic form, installation of the ZM3 is simply a matter of mounting the unit in a rack, connecting sources to the appropriate inputs and connecting zone outputs to power amplifiers.

The power supply should be securely mounted, and connected to the ZM3.

NOTE: XLR CONFIGURATION

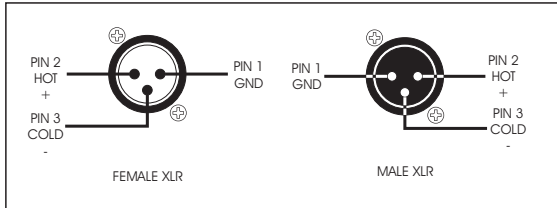

When wiring the outputs on the ZM3 as unbalanced, Pin2 should be wired as hot and Pin1 and Pin3 should be connected together and wired as ground/shield.

REMOTE CONTROLS

The remote control options on the ZoneMix3 are quite extensive and permit many possible situations to be accommodated. Remote control is achieved via the rear panel RJ45 (CAT5) socket. Below is a diagram of the pin out on the CAT5 cable.

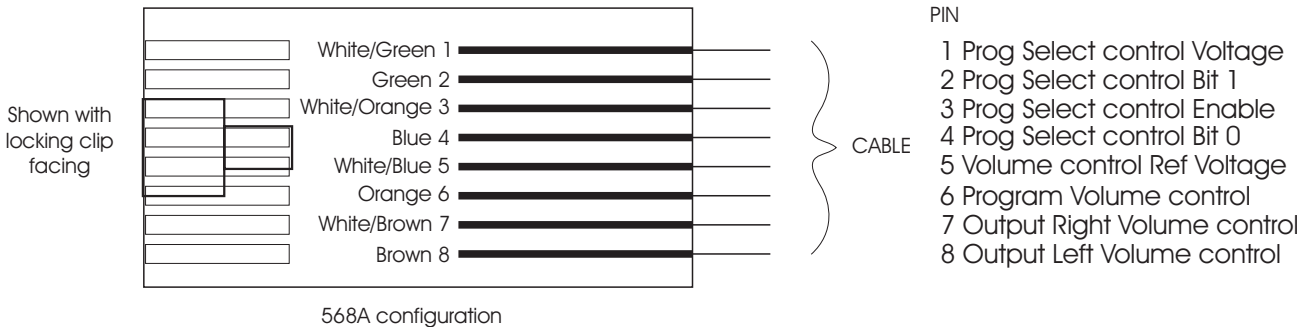

ZM3R

The simplest and most common use of the remote control features on the ZM3 is with the ZM3R Program Source select and level remote control panel (See page 18).

- A straight through wired Cat5 cable (not a crossover cable) should be used (wired pin 1 to pin 1, pin2 to pin2 etc, following the colour system as indicated above)
- Connect to the ZM3R which has a RJ45 socket on the back.
- Connect cable from remote panel(s) to REMOTE connector in relevant zone section of the ZM3.
- Press the remote enable switch on the rear panel of the ZM3.

Now the ZM3R has control of the program sources and the front panel controls do not effect the unit.

Simple Zone Masters

For volume control within the zone, an RC 1 can be used. This will provide control over a stereo

zone or individual sends on a mono zone. There is no need to enable the rear panel remote switch unless an ZM3R is also being used.

For Stereo the RC1 should be wired between pin 5 and pins 7 and 8 shorted together.

If each output is being used as an individual sub zone send then one RC1 can be wired between pin 5 and pin 7 (for Right sub zone send) and another RC1 between pin 5 and pin 8 (for Left sub zone send). The zone should be set to MONO, see Internal Adjustments on page 10.

PAGING STATION

See Paging Station on page 16 for more information.
Connect cable from ZM3M to PAGE MIC connector on the ZM3.

7. STEP BY STEP SETUP

NOTE: To avoid frustration, check the Internal Adjustments section BEFORE beginning setup!

The inputs of the ZM3 can accommodate a wide range of sources including active paging stations, dynamic microphones, DVD, CD players & DJ mixers. The zone outputs may be used to drive stereo power amplifiers, mixers, or mixer amplifiers.

Each installation will require setting the appropriate relative mix of levels between paging, program sources and mic/line inputs for each zone and balancing between the zones.

Because of the variation in levels between the possible sources, ZM3 offers a number of gain stage adjustments so you can set the correct levels for your application.

Also consider what the outputs are driving...

Setting up correct gain structure through the whole system is important to achieve optimal results.

The following step by step procedure has been devised to assist during the setup process.

Step by step setup

Ensure all gain adjustments on the ZM3 are at minimum.

Choose a zone that is conveniently located near to the ZM3 or further away if you feel you need the exercise.

This will be referred to as the "TEST ZONE".

Ensure that all amplifiers connected to the ZM3 are set to provide required sound levels with a line level input signal.

1. Select PROG1 in the TEST ZONE. Adjust the PROG TRIM until sufficient level is achieved in the TEST ZONE.
2. Repeat this process for Programs 2-4. The level of each program source should be of similar volume so no great variation in level apparent when selecting between program inputs
3. Check program level in the other 2 zones to confirm that the gain structure is appropriate for all amplifiers.
4. Do a test page in the TEST ZONE and check the level relative to the program level.
5. Adjust the page level as desired [front panel PAGE MIC].
6. EQ the paging mic as required
7. Set the Mic/Line input levels remembering these inputs are selectable to each zone from the front panel.
8. EQ the Mic/Line inputs.
9. Select the REMOTE ENABLE switch (rear panel) if the ZM3R is being used in each zone. This will allow remote source selection & zone volume adjustment.
10. The ZM3 features 5 band equalization to achieve precise equalization of high quality audio systems in demanding environments.
11. Repeat this process for the other 2 zones.

8. PAGING STATION

Introduction

The ZM3M is a slim line paging microphone that provides the user the ability to page into any combination of zones from a remote location. Running both audio & data down inexpensive & industry standard CAT5 cable the ZM3M is simple to install.

Controls

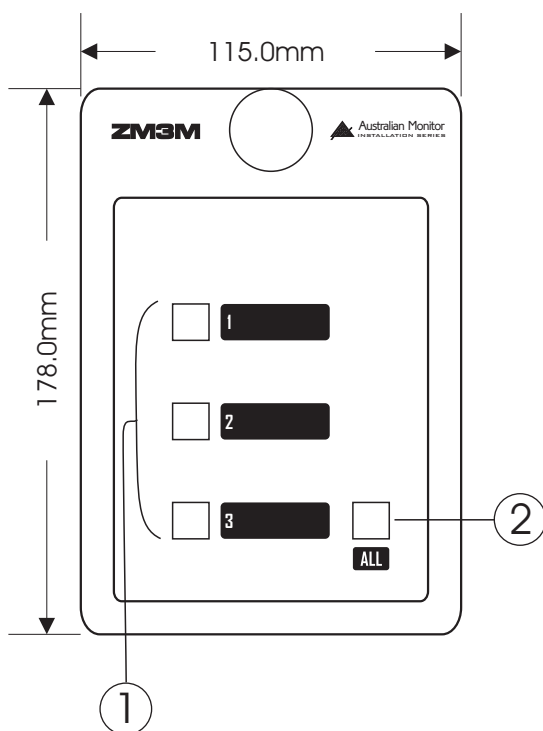

1 ZONE select

These buttons, when pressed, will page to that zone. With the button held down, talk into the microphone. There is a label space to the right of the button to allow labelling of the zone.

2. ALL page

This button allows paging to all zones. Hold down the button to talk.

3 GAIN

To accommodate different speech levels, there is a gain control on the base of the ZM3M. This ships set to minimum and may be adjusted to suit. Increasing this control too far may cause the paging station to distort if loud or close speech levels are encountered. Caution should be used if trying to achieve high gain levels for distant or lectern speech styles as feedback may occur.

Base Plate section

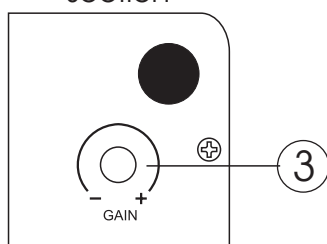

Installation and Setup

The CAT5 cable connects to the RJ45 socket on the rear panel of the paging station. This socket is a NEUTRIK™ connector designed to be used with the XLR style housing (model NE8MC) to improve reliability. Normal RJ45 connectors can also be used.

CABLE INSTALLATION FOR PAGING STATION

The RJ45 port (labelled Page Mic) on the rear of the ZoneMix3 is provided for connection to a ZoneMix3 Zone Paging Station, ZM3M. The CAT5 cable can be up to 30m long and should be routed as best as possible away from sources of high electromagnetic radiation (such as motors and dimmers).

NOTE: These are **NOT** Ethernet connections.

NOTE: If installing and terminating CAT5 cable is new to you, please take note of the various points that follow. As the CAT5 cabling for the DigiPageJr carries voltage, damage could occur if your pin-pin connections are not made correctly.

CAT5 CABLE

CAT5 cable is the blue cable commonly used for data installations (other colours do exist). It consists of four twisted pairs of wires: this is why it is often referred to as UTP (Unshielded Twisted Pair). The most readily available cable uses solid conductors, like telephone wire. Cable with stranded conductors is available, and is more flexible.

CAT5 TERMINATION

Pre-wired CAT5 cable comes in two configuration standards, 568A and 568B. It is advisable to carry a good pre-wired cable for fault-finding. Both configurations will work with the DigiPageJr provided both ends have the same configuration. Be careful not to use a crossover cable which has one configuration at one end and the other configuration at the other end.

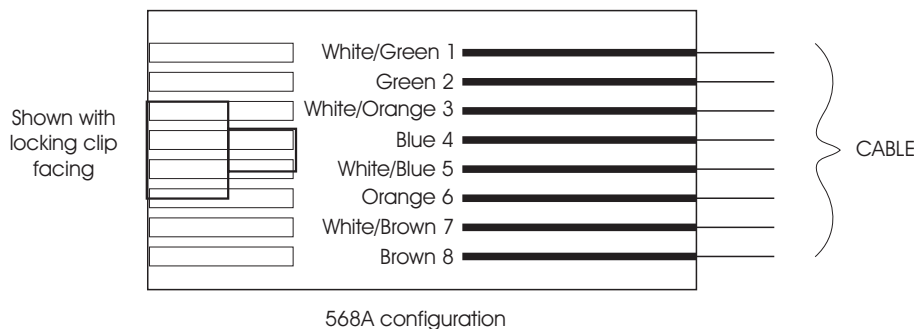

Ensure that the RJ45 connectors are suited to the cable used (solid or stranded) and that the correct crimp tool is used.

NOTE: CAT5 cable consists of four pairs of wires: it is not sufficient to simply wire the two ends pin for pin, ignoring pairing.

9. ZM3R REMOTE CONTROL PANEL

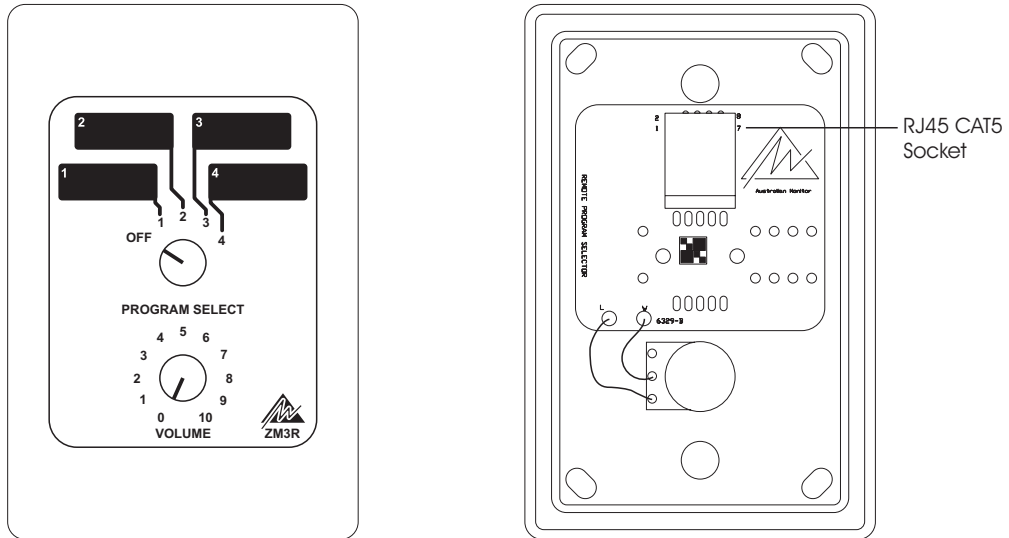

Introduction

The ZM3R is a simple yet stylish accessory for the Zonemix 3 that allows for source selection & volume control from a remote zone. It features ample label space and a contemporary black decor. Running via industry standard CAT5 cable, the ZM3R is another product from Australian Monitor Installation Series that provides a simple yet elegant solution to a complex zoning application.

Installation

Remote control is achieved via the rear panel RJ45 (CAT5) socket. Connection is via CAT5 cable and a distance of up to 1000m is guaranteed.

A straight through wired Cat5 cable (not a crossover cable) should be used (wired pin1 to pin1, pin2 to pin2 etc)

- Connect to the ZM3R RJ45 socket on the back and to the zone remote RJ45 on the rear of the ZM3.
- Press the remote enable switch on the rear panel of the ZM3.

Now the ZM3R has control of the program sources and the front panel controls do not effect the unit.

Below is a diagram of the pin out on the CAT5 cable.

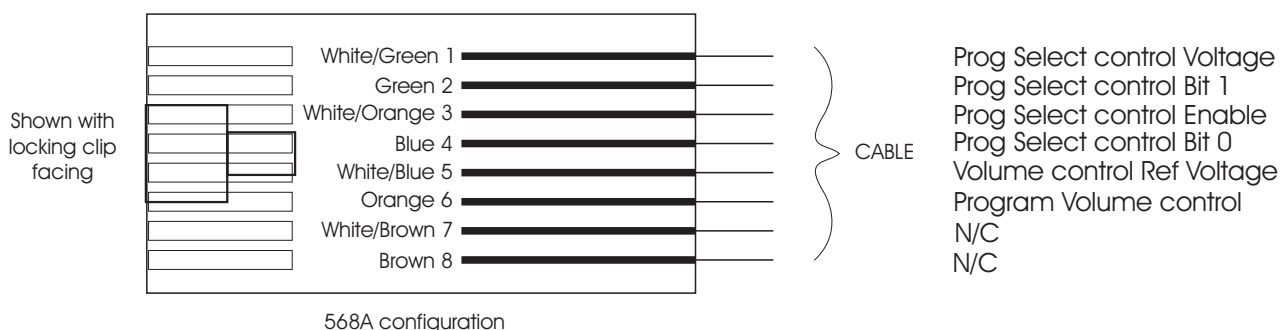

NOTE: CAT5 cable consists of four pairs of wires: it is not sufficient to simply wire the two ends pin for pin, ignoring pairing.

NOTE: If installing and terminating CAT5 cable is new to you, please take note of the various points that follow. As the CAT5 cabling for the DigiPageJr carries voltage, damage could occur if your pin-pin connections are not made correctly.

CAT5 CABLE

CAT5 cable is the blue cable commonly used for data installations (other colours do exist). It consists of four twisted pairs of wires: this is why it is often referred to as UTP (Unshielded Twisted Pair). The most readily available cable uses solid conductors, like telephone wire. Cable with stranded conductors is available, and is more flexible.

CAT5 TERMINATION

Pre-wired CAT5 cable comes in two configuration standards, 568A and 568B. It is advisable to carry a good pre-wired cable for fault-finding. Both configurations will work with the DigiPageJr provided both ends have the same configuration. Be careful not to use a crossover cable which has one configuration at one end and the other configuration at the other end.

Ensure that the RJ45 connectors are suited to the cable used (solid or stranded) and that the correct crimp tool is used.

NOTE: These are **NOT** Ethernet connections.

Dimensions

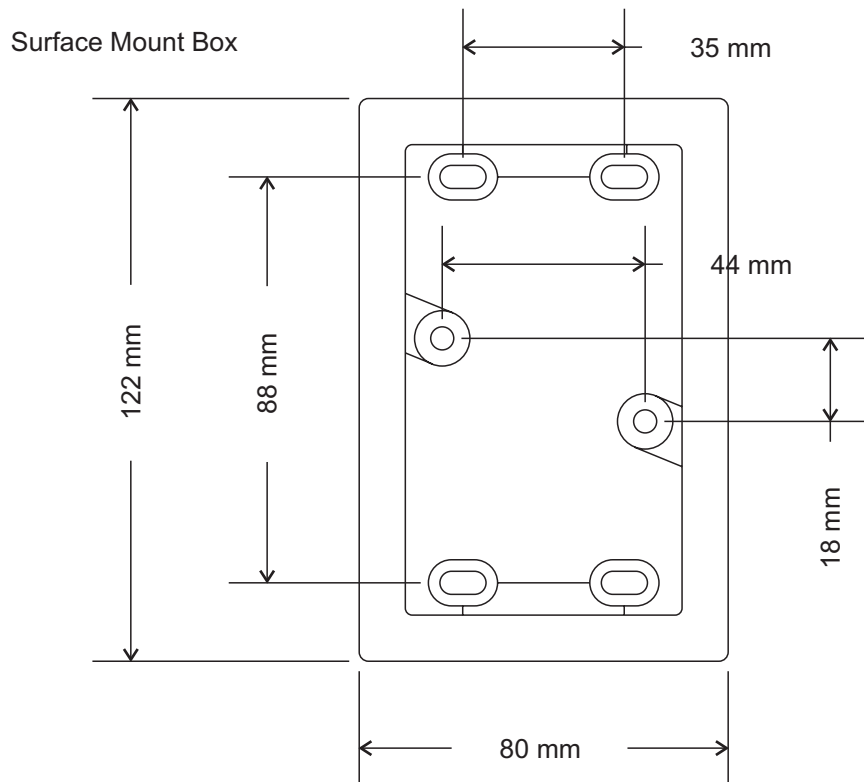
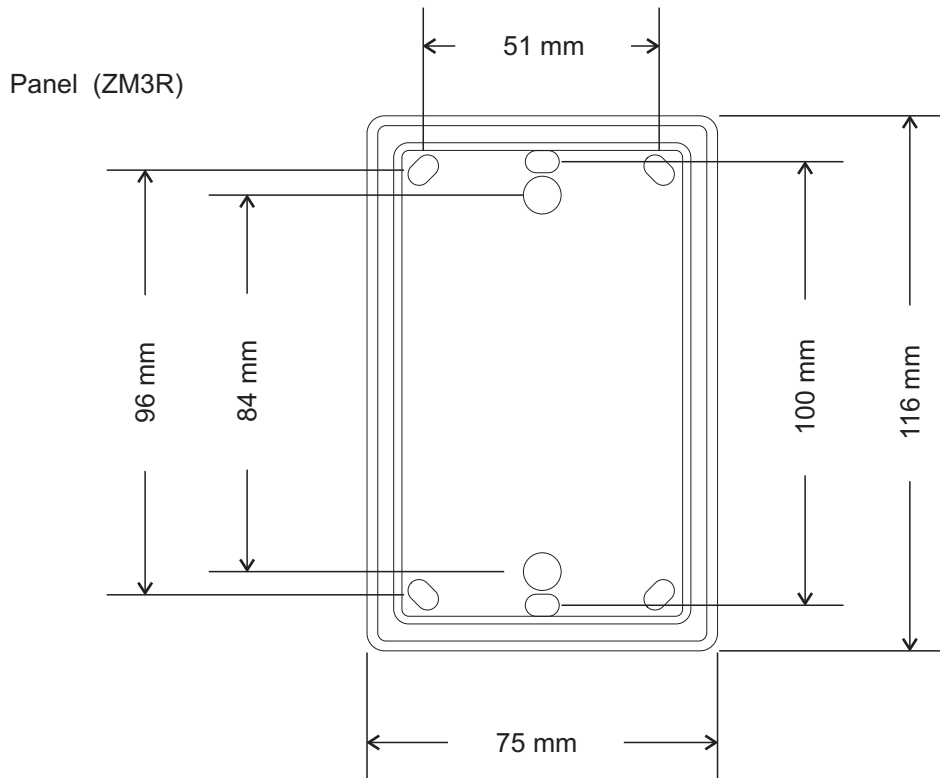

10. DIMENSIONS

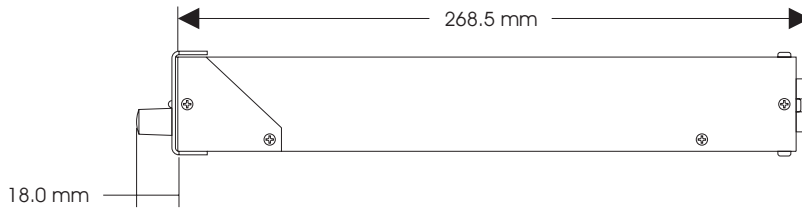
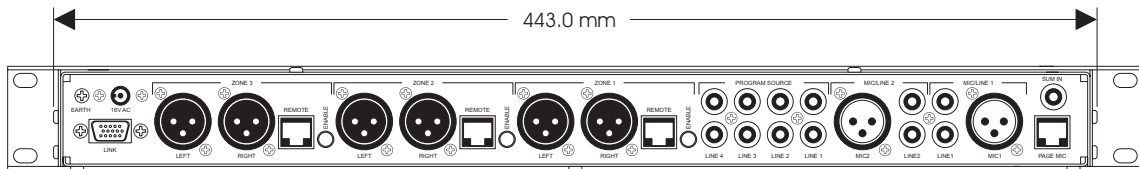
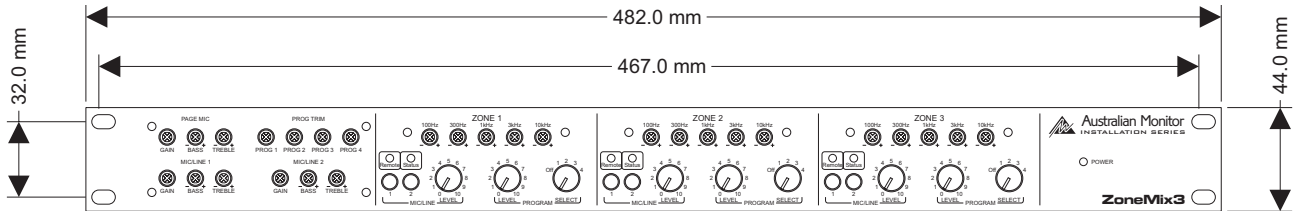

11. BLOCK DIAGRAM

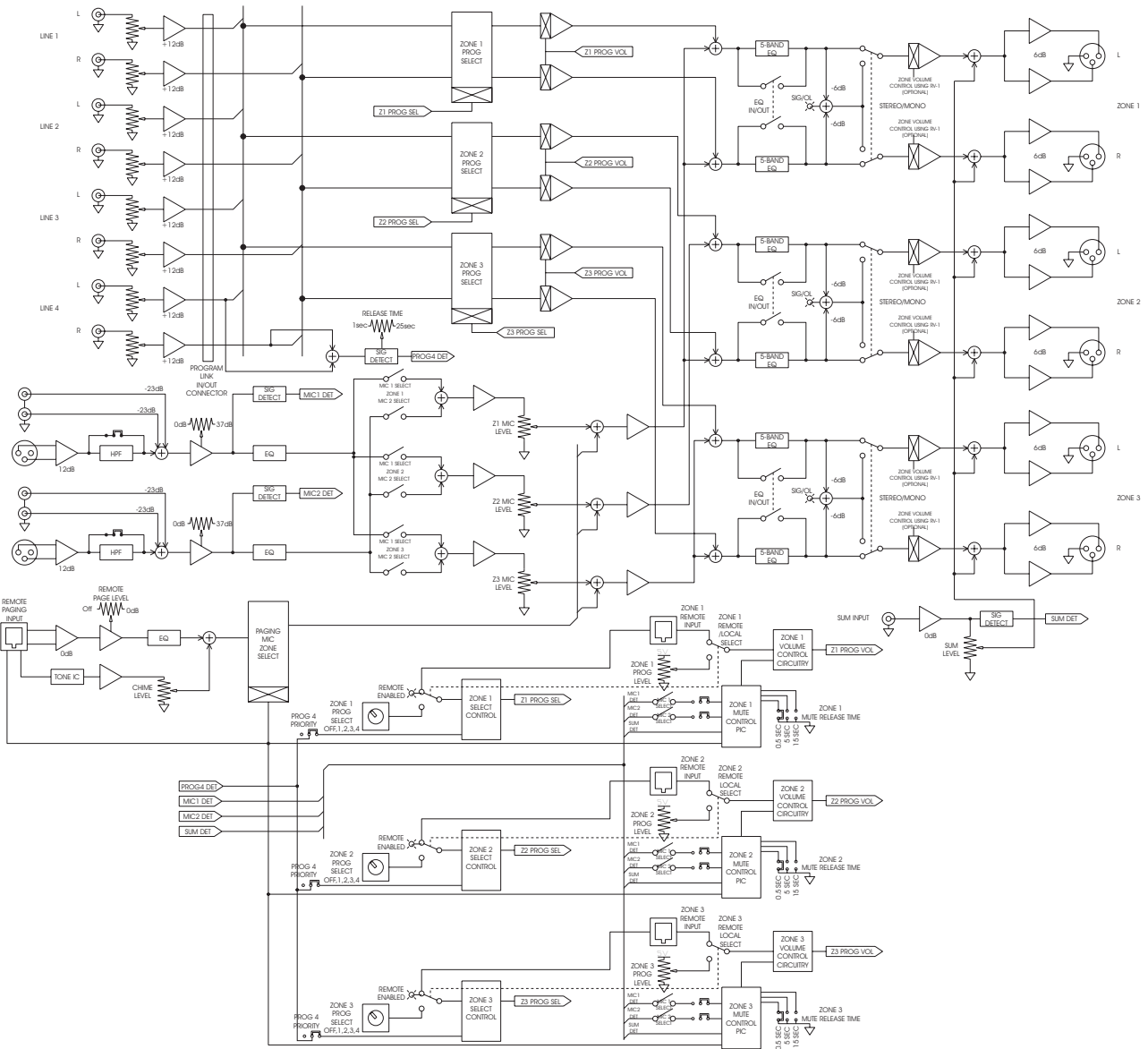

12. SPECIFICATIONS

-Dimensions:	44.0 x 482.0 x 286.5 (HxWxD) mm
-Weight:	Net 2.5kg Shipping 3.0kg Net 5.5lb Shipping 6.6lb
-Power Input:	20VAC 30VA max
-Sensitivity (for 0dB out):	Mic/Line Input (RCA) 86mV (-19dB) Mic/Line Input (XLR) 1.55mV (-54dB) Prog Input (RCA) 190mV (-12dB)
-Max Level Out:	10Vrms (+22dB)
-Frequency Response: (0dB/-3dB)	20Hz - 20kHz
-THD:	less than 0.1%
-Noise:	-80dB
-Crosstalk:	Better than 65dB
-Phantom Power:	15VDC

All measurements referenced to 0dBu (0.775mV)
All measurements done with levels set to max

AUSTRALIA and NEW ZEALAND

www.australianmonitor.com.au

Sydney

(NSW & ACT Sales)

Private Bag 149, Silverwater NSW 1811
149 Beaconsfield Street, Silverwater NSW 2128
Ph: (02) 9647 1411
Fax: (02) 9648 3698
E-mail: nsw@audiotelx.com.au

Brisbane

(Qld Sales)

P.O. Box 871, Fortitude Valley QLD 4006
42 Commercial Road, Fortitude Valley QLD 4006
Ph: (07) 3852 1312
Fax: (07) 3252 1237
E-mail: qld@audiotelx.com.au

Perth

(WA Sales)

P.O. Box 404, North Perth WA 6906
299 Fitzgerald Street, West Perth WA 6005
Ph: (08) 9228 4222
Fax: (08) 9228 4233
E-mail: wa@audiotelx.com.au

Melbourne

(Vic & Tas Sales)

P.O. Box 151, Blackburn South VIC 3130
22/277 Middleborough Road, Box Hill VIC 3128
Ph: (03) 9890 7477
Fax: (03) 9890 7977
E-mail: vic@audiotelx.com.au

Adelaide

(SA & NT Sales)

P.O. Box 157, Hindmarsh SA 5001
31 Walsh Street, Thebarton SA 5031
Ph: (08) 8352 4444
Fax: (08) 8352 4488
E-mail: sa@audiotelx.com.au

Auckland

(NZ Sales)

P.O. Box 512, Albany 1331
Unit B, 11 Piermark Drive, Albany 1331
Ph: (09) 415 9426
Fax: (09) 415 9894
E-mail: audiotlx@nznet.gen.nz

EUROPE/ASIA/MIDDLE EAST

www.australianmonitor.com.au

International Sales

Private Bag 149, Silverwater NSW 1811
149 Beaconsfield Street, Silverwater NSW 2128
Australia
Ph: 61-2- 9647 1411
Fax: 61-2-9748 2537
E-mail: international@audiotelx.com.au

USA/CANADA/SOUTH AMERICA

www.australianmonitor.com

Australian Monitor Audio Inc.

PO Box 3126, Lynnwood, WA 98046
Ph: 425 673 5175
Fax: 425 673 7825
E-mail: sales@australianmonitor.com

